

Clamping bolts



Quick setting with the clamping bolts: move each single bolt without clamping screw into the slide block of the machine table and position the bolt by hand as a stopper at the workpiece. Tighten the clamping bolt and it automatically helps you to position the workpiece.

Flexible for diverse workpiece shapes: no matter if round, oval, quadratical or even pentagonal - with the help of the clamping bolts, you can clamp all forms.



Safely fixed: the clamping screws are added from above. They clamp the workpiece powerfully and securely. A soft exchangeable brass ring avoids damages or scratches at the workpiece.

Drill-through: there is not much disturbing space under the workpiece - no clamping jaws, no base, nothing is disturbing when you drill-through your workpiece with diverse divisions of pitch circles.

The small disturbing contour enables multi-purpose machining even at places which you normally hardly reach.

Clamping bolt system FlexiClamp



You only buy what you need!

Build your own clamping system!

Full flexibility thanks to the modular principle

New, incredibly fast and individual application: FlexiClamp

Assemble your FlexiClamp clamping system with the parts you need for your machining!

The FlexiClamp bolts are a modern combination of an aluminum body and hardened steel surfaces. The bolts are available in heights of 50 and 80 mm.

The bolts are positioned and fastened using a centric screw with a hexagonal wrench while the bolt is stationary - without any undesired twisting.

You can reach any position on the machine table with the help of the transvers T-slot bar:

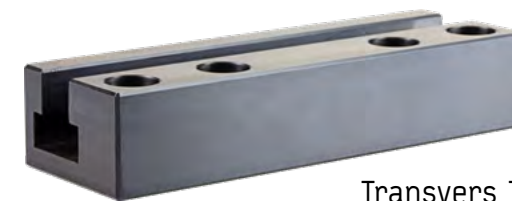

Transvers T-slot bar
Art.No. 003S00Z40



FlexiClamp is also suitable for series production, since the workpiece can be changed in just a few simple steps using the bearing clamping screw:



FlexiClamp

FlexiClamp

Decide which screw you need:



Art.No. 003S01000
Standard screw for small to medium-sized series: minimized interfering contours thanks to the very flat screw head.



Art.No. 003S02000
Bearing clamping screw also for large series: Faster workpiece changes due to the innovative contour of the bearing screw head.

Decide which clamping height you need:

Stable extension of the clamping height by 20 or 40 mm through a rigid extension with the same clamping screw length:



Clamping bolt height 50 mm
Art.No. 003S00050



Clamping bolt height 80 mm
Art.No. 003S00080



Clamping ring (for bearing clamping screw)
Art.No. 003S00Z22



Clamping ring standard
Art.No. 003S00Z21



Transvers T-slot bar
Art.No. 003S00Z40



Slide block
10 - 18 mm

Order data:

| Article No. | Description |
|-------------|------------------------------------------------------------------------------------------|
| 003S01050 | FlexiClamp Set clamping bolt M8 height 50 mm + clamping screw standard |
| 003S01080 | FlexiClamp Set clamping bolt M8 height 80 mm + clamping screw standard |
| 003S02050 | FlexiClamp Set clamping bolt M8 height 50 mm + bearing clamping screw |
| 003S02080 | FlexiClamp Set clamping bolt M8 height 80 mm + bearing clamping screw |
| 003S00050 | FlexiClamp clamping bolt M8 height 50 mm |
| 003S00080 | FlexiClamp clamping bolt M8 height 80 mm |
| 003S01000 | FlexiClamp clamping screw standard 5-25 mm |
| 003S02000 | FlexiClamp bearing clamping screw 5-25 mm |
| 003S00Z11 | FlexiClamp clamping bolt extension +20mm |
| 003S00Z12 | FlexiClamp clamping bolt extension +40mm |
| 003S00Z21 | FlexiClamp clamping ring standard |
| 003S00Z22 | FlexiClamp clamping ring for bearing clamping screw |
| 003S00Z40 | FlexiClamp transvers T-slot bar 14 mm (for suitable T-slot distances 63, 100 and 125 mm) |
| 002080028 | Slide block M8 x 10 |
| 002140301 | Slide block M8 x 12 |
| 002140327 | Slide block M8 x 14 |
| 002153460 | Slide block M8 x 16 |
| 002153478 | Slide block M8 x 18 |



Clamping bolts

Conventional steel design

Clamping bolts



Clamping bolt 50 mm
with thread
M10 oder M12



Clamping bolt 100 mm
with exchangeable
threaded bolt



Clamping bolt 150 mm
with exchangeable
threaded bolt

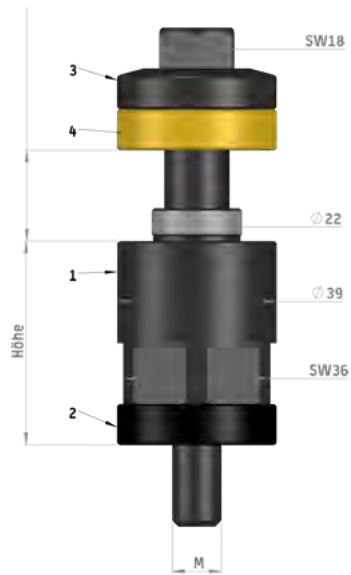

- 1 - clamping bolt
- 2 - spring washer
- 3 - clamping screw
- 4 - clamping ring
- 5 - threaded bolt

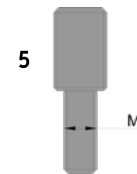

Type:

Flexible clamping tool for direct clamping on the machine table with direct fixation in the T-slot. Precise tolerance classes guarantee parallel clamping to the machine table. For the bolts with length 100 mm and 150 mm, exchangeable threaded bolts are available. The clamping ring prevents a damage of the workpiece.

Almost all types of flat workpieces can be clamped powerfully and precisely with these clamping bolts. The standard clamping range is 8-40 mm. With the clamping screws (available as spare part) it can be widened to a maximum of 87 mm.



Scope of delivery for height 50 mm:

Clamping bolts with fixed thread, ring & clamping screw with clamping ring

| Article No. | Description | Height | Thread |
|-------------|---------------|--------|--------|
| 003000050 | Clamping bolt | 50 mm | M10 |
| 003M12050 | Clamping bolt | 50 mm | M12 |

Scope of delivery for height 100 mm/150 mm:

Clamping bolts, threaded bolt M10, ring & clamping ring with clamping screw

| Article No. | Description | Height | Thread |
|-------------|---------------|--------|--------|
| 003000100 | Clamping bolt | 100 mm | M10 |
| 003000150 | Clamping bolt | 150 mm | M10 |

Spare parts for clamping bolts

| Article No. | Description | Thread |
|-------------|----------------|---------------|
| 003000Z00 | Washer | - |
| 003000Z02 | Clamping ring | - |
| 003000Z01 | Clamping screw | 8 mm - 40 mm |
| 003000Z03 | Clamping screw | 40 mm - 67 mm |
| 003000Z04 | Clamping screw | 65 mm - 87 mm |
| 003000M10 | Threaded bolt | M10 |
| 003000M12 | Threaded bolt | M12 |
| 003000M14 | Threaded bolt | M14 |
| 003000M16 | Threaded bolt | M16 |

Set of clamping bolts

Delivery includes:

3 pcs. clamping bolts length 50 or 100, 3 pcs. clamping screw 40-67, 3 pcs. clamping screw 65-87, 1 pcs. The set is in a high-quality wooden case.

| Article No. | Description | Height | Thread |
|-------------|-------------------|--------|--------|
| 003990050 | Clamping bolt set | 50 mm | M10 |
| 003990100 | Clamping bolt set | 100 mm | M10 |



Clamping bolts

